

DP9300 / DP9100 / DP9301 / DP9101

DOLPHIN BABY CHANGING UNITS

MANUAL



April 2024

D
DOLPHIN

CONTENTS

**VERY IMPORTANT. SAVE THESE INSTRUCTIONS FOR FUTURE REFERENCE.
READ AND KEEP IN MIND ALL INSTRUCTIONS AND RECOMMENDATIONS
DESCRIBED THROUGHOUT THIS MANUAL.**

3	Liability and warranty
4-6	General safety instructions
7-15	Product description
16-20	Mounting
21-22	First use
23	Assistance with faults
24-25	Maintenance
26	Detergents
27	Disposal

LIABILITY AND WARRANTY

Any liability and warranty of the manufacturer is excluded if

- › The product is not used as intended
- › The notices and instructions in the instructions for use are not observed
- › The product, including accessories, is used incorrectly
- › The product, including accessories, is not maintained or is improperly maintained
- › The product, including accessories, is improperly repaired and non-genuine spare parts are used
- › Modifications and functional changes are made without the manufacturer's consent.

Any liability and warranty of the manufacturer is expressly excluded if

- › The product is damaged due to inadequate fastening or exceeding the max. load of 15kg.

Warranty claims on the manufacturer are governed by the Terms and Conditions of Sale and Delivery of

Dolphin Solutions Ltd
Southpoint
Compass Park
Junction Rd
Bodiam
Robertsbridge
TN32 5BS

Subject to technical modifications!

Due to constant further development, illustrations, function steps and technical data may differ slightly.

GENERAL SAFETY INSTRUCTIONS



These instructions for use have been created specifically for the service personnel of baby changing table DP9300 / DP9100 / DP9301 / DP9101. They contain important information for mounting, using and cleaning the system.

DUTY OF CARE OF THE USER

The baby changing table has been designed and constructed through careful selection of the harmonised standards to be observed, as well as other technical specifications. It therefore conforms to the latest technology and guarantees the highest possible degree of safety.

However, this degree of safety can be achieved in practice only if all the measures required for this purpose have been taken. The user of the product has a duty of care to plan these measures and to monitor the implementation thereof.

The user must ensure in particular that

- › The product is used only as intended (cf. also the product description section).
- › The product is used only in a faultless, fully functional condition.
- › The instructions for use are legible and complete at all times.
- › Only adequately qualified and authorised personnel maintain and repair the product.
- › These personnel are regularly instructed in all relevant issues concerning occupational safety and environmental protection, and also that these personnel understand the instructions for use and in particular the safety instructions contained therein.
- › All safety and warning notices attached to the product are not removed and remain legible.

GENERAL SAFETY INSTRUCTIONS

EXPLANATION OF THE SAFETY SYMBOLS USED



CAUTION

Indicates a potentially hazardous situation which, if the safety regulations are not observed, can result in property damage, minor or moderate physical injury.



IMPORTANT

For instructions for use and other useful information.

BASIC SAFETY MEASURES

It must be guaranteed that all persons who have to undertake activities on the product can view the instructions for use at all times. In addition to the instructions for use, operating instructions as defined in the Occupational Safety and Health Law and the Equipment Usage Directive shall be provided.

All safety notice signs and operating information signs on the product must be readily legible at all times. Signs that have become damaged or illegible must be replaced immediately.

The baby changing tables are not designed for use by any persons (including children) with limited physical, sensory or mental aptitude or lack of experience and/or lack of knowledge, unless they are supervised by a person responsible for their safety or have received instruction from this person as to how the product is used.

Children should be supervised to ensure that they do not play with the product.

REQUIREMENTS FOR SERVICE PERSONNEL

The product may only be maintained by persons who are trained, instructed and authorised to do so. These persons must understand these instructions for use and act accordingly. The respective authorities of the operating personnel must be clearly defined.

All persons who undertake activities on the product must read the instructions for use and sign to confirm that they have understood the instructions for use.

GENERAL SAFETY INSTRUCTIONS

SPECIAL HAZARD TYPES



Caution! Crushing hazard!

When relocating the product, it is important to ensure that no body parts are placed between the product and the vicinity or fixture.



Caution! Crushing hazard!

When closing the door, it is important to ensure that fingers are not placed between the door and the product carcass.



Attention!

All fittings must be adequately tightened and checked on a regular basis.



Attention!

For mounting the baby changing table on or in the wall, the fastenings used must be suitable for the corresponding wall type.



Attention! Burning hazard

Do not mount any strong heat sources, such as radiant heaters for example, in the immediate vicinity of the baby changing table.



Attention!

The baby changing table is designed for a child with a maximum weight of 15 kg.



Attention!

All accessories and spare parts must be obtained only from the manufacturer.



Attention! Injury hazard

Do not use the baby changing table if a part is faulty, torn-off or missing.

PRODUCT DESCRIPTION



The baby changing table is a product for changing a child with a maximum weight of 15kg.

Thanks to the space-saving folding mechanism, the baby changing table can also be used in confined spaces.

Surface and flush-mounted variants in vertical and horizontal design are available.

Full metal housing in robust, easy-to-clean chromium nickel steel, 1.4301, satin finish. Grip rail with smooth surface IIIID, all edges fully welded.

The lying surface is easy to open and close via a maintenance-free, gas strut-supported lifting mechanism.

Lying surface from grey polypropylene, seamless, deep drawn, without visible fastenings, replaceable.

PRODUCT DESCRIPTION

INTENDED USE

- › The baby changing table is intended for changing a baby or a child up to a maximum weight of 15kg.
- › The baby changing table may be used only when in a technically faultless condition. Faults must be rectified immediately. A faulty product must be taken out of service immediately.
- › Instruct the cleaning and operating personnel on use and in particular on the maintenance requirements.
- › The instructions for use must be followed when using the baby changing table for the first time.
- › Do not use cleaning materials which can lead to damage if used incorrectly. (see Cleaning section)



Using the baby changing table contrary to the intended use will render the warranty invalid. Furthermore, the manufacturer shall not be held liable in this case.

In particular, we point out that the product must not be used to store items of luggage or as a seat. Moreover, the baby changing table must be used for one child only, not several children.

PRODUCT DESCRIPTION

STRUCTURE OF THE BABY CHANGING TABLE

> DP9300 - ++Horizontal Baby Change - Recessed

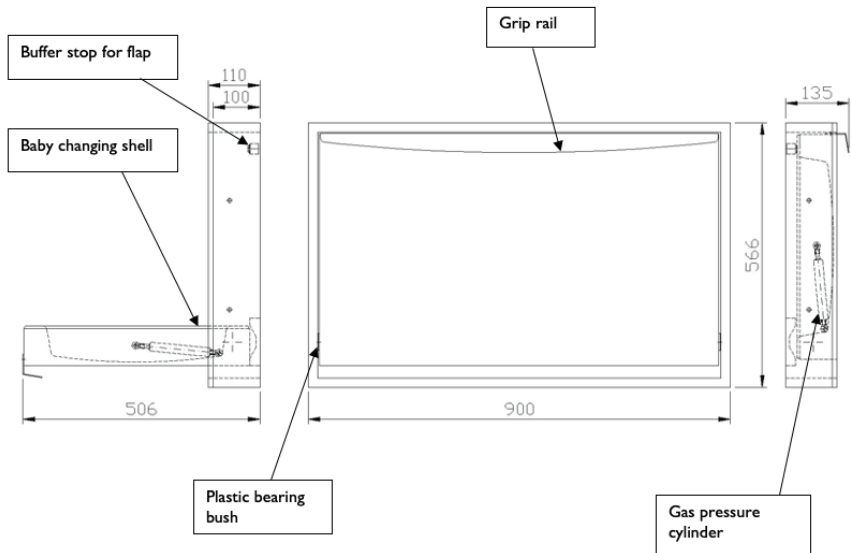

PRODUCT DESCRIPTION

> DP9100 - ++Horizontal Baby Change - Surface Mounted

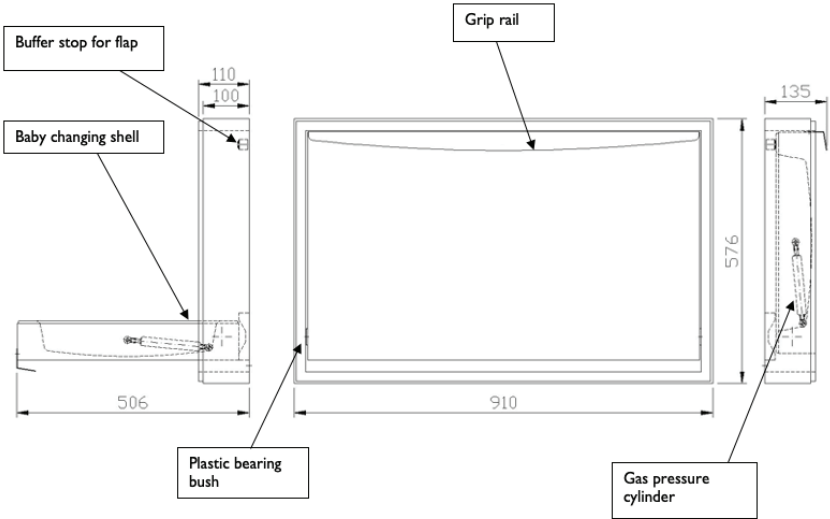

PRODUCT DESCRIPTION

> DP9301 - ++Vertical Baby Change - Recessed

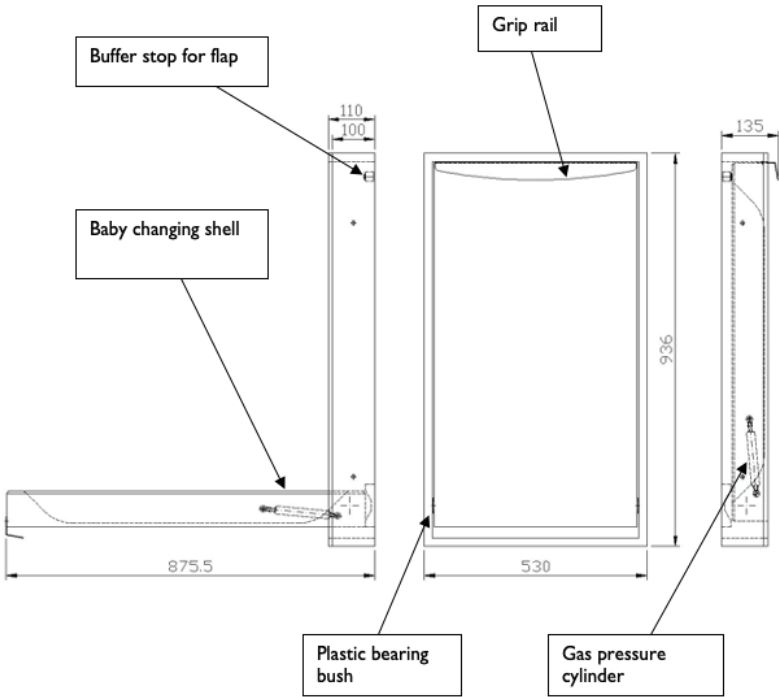

PRODUCT DESCRIPTION

> DP9101 - ++Vertical Baby Change - Surface Mounted

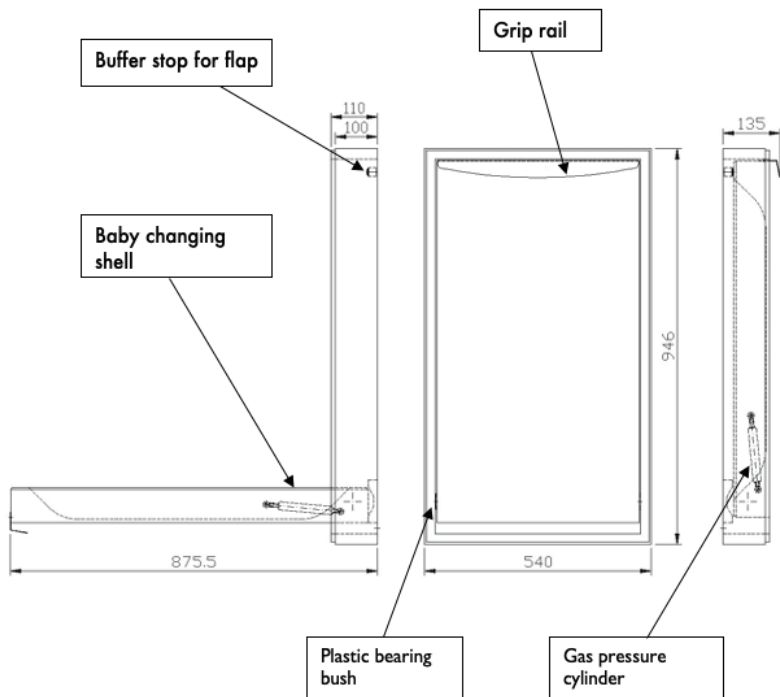

PRODUCT DESCRIPTION

TECHNICAL DATA

> DP9300 - ++Horizontal Baby Change - Recessed

General	
Dimensions length x width x height	900 x 566 x 135 mm
Empty weight	23.7 kg
Environmental conditions	
Ambient temperature	+10°C to +45°C

> DP9100 - ++Horizontal Baby Change - Surface Mounted

General	
Dimensions length x width x height	910 x 576 x 135 mm
Empty weight	23.7 kg
Environmental conditions	
Ambient temperature	+10°C to +45°C

PRODUCT DESCRIPTION

> DP930I - ++Vertical Baby Change - Recessed

General	
Dimensions length x width x height	530 x 936 x 135 mm
Empty weight	25.2 kg
Environmental conditions	
Ambient temperature	+10°C to +45°C

> DP910I - ++Vertical Baby Change - Surface Mounted

General	
Dimensions length x width x height	540 x 946 x 135 mm
Empty weight	25.2 kg
Environmental conditions	
Ambient temperature	+10°C to +45°C

PRODUCT DESCRIPTION

AS-DELIVERED CONDITION AND SCOPE OF DELIVERY

- As-delivered condition:**
- > Packed in a box
 - > With protective film for the CNS surface (outside)
- Scope of supply:**
- > Baby changing table
 - > Instructions for use for baby changing table
 - > Mounting materials

TRANSPORT AND UNPACKING

What has to be done?	Who does it?
Unload, transport and unpack packed product, dispose of the packaging.	Transport specialist



- > Remove external packaging.
- > Lift the product out of the box.
- > Dispose of films, solid foam and box separately (observe local regulations).
- > Check consignment for completeness and integrity.

MOUNTING

MOUNTING DP9300, DP9301

The baby changing table must be mounted sideways on a wall recess using the mounting materials provided (4x hexagonal head screws $\text{Ø}6 \times 50$, 4x dowels $\text{Ø}8\text{mm}$). A 10 mm AF open-ended spanner or socket wrench is required. All 4 fastenings facilities must always be used. The baby changing table is supplied fully-assembled and ready-for-use. No assembly work is required on the baby changing table.



Attention!

All fittings must be adequately tightened and checked on a regular basis. It must be ensured that the wall structure can withstand the load of the baby changing table.

Fastening points DP9300

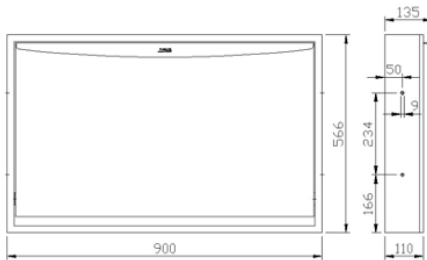

Wall recess: 901 x 567mm
Depth: 112mm

Fastening points DP9301

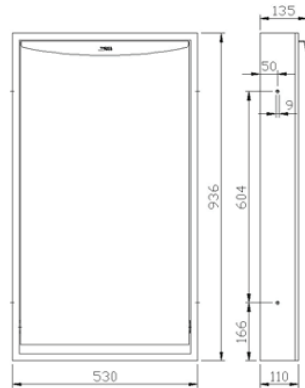

Wall recess: 531 x 937mm
Depth: 112mm

MOUNTING

MOUNTING DP9100, DP9101

The baby changing table must be mounted on a flat, smooth wall using the mounting materials provided (4x countersunk head screws $\text{Ø}6 \times 50$, 4x dowel $\text{Ø}8\text{mm}$). A size 5 hexagon socket wrench is required. All 4 fastenings facilities must always be used. The baby changing table is supplied fully-assembled and ready-for-use. No assembly work is required on the baby changing table.



Attention!

All fittings must be adequately tightened and checked on a regular basis. It must be ensured that the wall structure can withstand the load of the baby changing table.

Fastening points DP9100

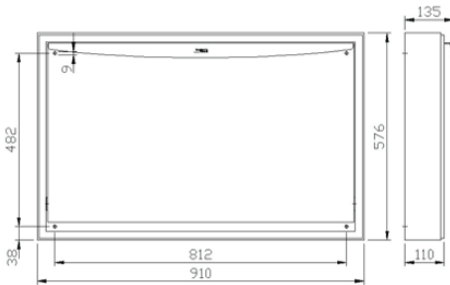

Fastening points DP9101

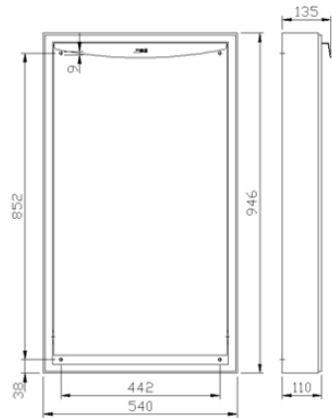

HORIZONTAL ARRANGEMENT OF THE BABY CHANGING TABLE

DP9100

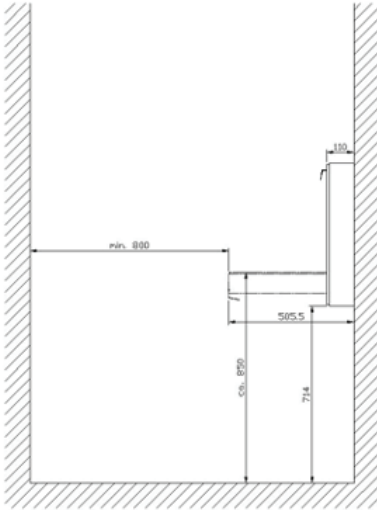

DP9300

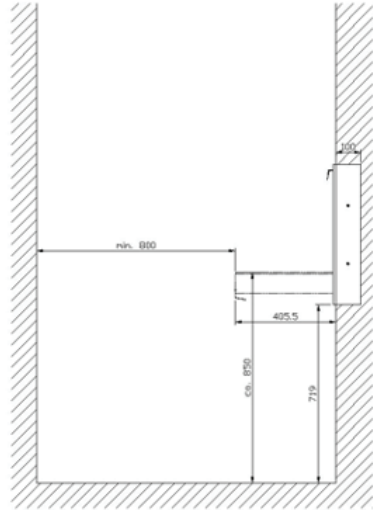

- > The lateral distance to the existing wall must be sufficiently large to allow the flap to be opened and to prevent any risk of fingers, clothing, etc. becoming trapped.

VERTICAL ARRANGEMENT OF THE BABY CHANGING TABLE

DP910I

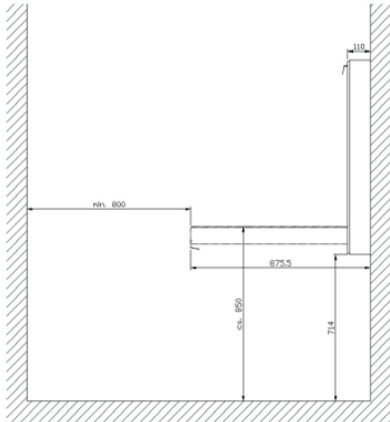

DP930I

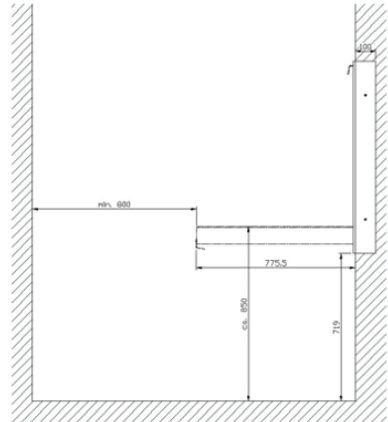

- > The lateral distance to the existing wall must be sufficiently large to allow the flap to be opened and to prevent any risk of fingers, clothing, etc. becoming trapped.

MOUNTING

MOUNTING SEQUENCE

- › Check whether the wall structure will allow the baby changing table to be securely mounted.
- › Drill mounting holes as per dimensional sketch 4.1 to 4.4 and insert dowels provided.
- › Open the flap and mount the baby changing table on the wall or in the wall using the screws provided.
- › Tighten the screws.
- › Check the functionality. - Flap must open only when pulled gently. (Flap must not drop down by itself)

FIRST USE

FIRST USE

The product is used for the first time by the operator.



Important!

Before first use:

- › Remove the film from the sheet surface
- › Thoroughly clean the inside and outside of the baby changing table (see Cleaning section)

CHECKING THE FUNCTION

- › Check the baby changing table for correct fastening.
- › In the closed position, the flap must open only when pulled gently. (Flap must not drop down by itself)

OPERATION / SAFETY INSTRUCTIONS



Warning!

Risk of injury or property damage through improper use of the baby changing table



Caution!

Do not use running water or even high-pressure cleaners for cleaning! (see Cleaning section).

Clean the product only with a damp cloth.



Warning! Injury hazard from falling

Do not leave your child unattended



Warning! Burning hazard

Do not mount radiant heaters or other heat sources capable of heating up the stainless-steel sheet parts



Warning!

The child to be changed must not weight more than 15kg



Warning!

The baby changing table must not be used if any part is faulty, torn-off or missing.

ASSISTANCE WITH FAULTS

- › Repair work must only be carried out by Service.
- › In case of faults, please contact the customer service department at Dolphin Solutions, stating the product type and the product number. (see identification plate)
- › The address of your service partner can be found on the last page of the instructions for use.

OVERVIEW OF POSSIBLE FAULTS AND REMEDIES

Elimination

Symptom / cause	Remedy	Who?
Flap drops down without resistance › Gas struts faulty	Replace the gas struts	Service
Flap has lateral clearance › Fulcrum pins are loose › Plastic bush is faulty	Retighten the fastening screws Replace plastic bush	Service Service
Flap does not close flush with the housing › Rubber buffer stop faulty	Replace rubber buffer stop	Service

CLEANING



General:

In order to maintain the hygienic conditions, the operating personnel must understand the Cleaning section.



Caution!

Do not use a water jet or high-pressure cleaner for cleaning!
Clean the product only with a damp cloth.



Caution! Material damage!

Acidic detergents must not contain salt or hydrofluoric acids, as these can lead to discolouration of the surface or even rusting.

Detergents must be used in accordance with the manufacturer's instructions.

Stubborn stains require intensive cleaning, e.g. with a soft synthetic fleece. Then wash down with clear water.

Clean the product only with the detergents intended for this purpose and use only a small amount of water.



Warning!

Risk of injuries on sheet edges of the doors and carcass

MAINTENANCE

CLEANING FOR THE FIRST TIME



Once the product has been mounted, it must be cleaned to remove all construction and/or mounting residues.

Use non-abrasive or acidic detergents for cleaning.

ONGOING CLEANING



Scour-free detergents must be used for cleaning.

Grease contamination and lipophilic pigment soiling are easily removed by means of

Multipurpose cleaners

Neutral cleaners

Alkali cleaners

cleaners.

To remove extremely stubborn grease contamination (congealed oils and fats) use

solvent cleaners and

scour-free emulsions.

INTERIOR CLEANING



Caution!

The surface of the plastic baby changing shell can be damaged through improper cleaning.

- > Clean the product with a warm, mild detergent solution. The surface should then be rubbed dry with a soft cloth.

DETERGENTS

Using incorrect detergents can damage the high-quality surfaces and cause them to lose their dirt-repellent effect.

The following table provides an overview of suitable detergents.

Agent	Comment
Mechanical detergent	
Bristle products	Brushes with natural or plastic bristles are well suited
Textiles	Textiles from natural and chemical fibres as cleaning fibres (cotton waste) and textile fabrics (knitted and woven fabrics, cleaning cloths, scouring pads, loose thread material, (fleece). Cleaning textiles from microfibres are highly suitable for removing finger marks from stainless steel and chromium nickel surfaces.
Synthetic fleece	without abrasive grains.
Other	Natural leather (chamois leather), imitation leather, synthetic fleece, sponges, sponge cloths
Chemical detergents	
Multipurpose cleaners	Especially for lighter grease contamination
Neutral cleaners	For surfaces contaminated by oil and grease (fingerprints); also suitable as dishwashing liquid.
Alcohol cleaner	As multipurpose cleaner
Alkali cleaners	Especially for stubborn grease and oil contamination (solidified oils)
Solvent cleaners	Depending on type, especially good at removing: grease, oil, wax, tar, adhesives, lacquers, paints.
Scour-free emulsion cleaner	Especially for stubborn grease contamination, paints
Disinfectant cleaner	Effect on pathogens - varies depending on disinfectant agent. Use products which appear in the list of the German Society for Hygiene and Microbiology (DHGM).
Acidic cleaners	Removes contamination such as limescale deposits, rust deposits, lipophilic pigment soiling, lighter grease contamination.

DISPOSAL

- › Your product consists of high-quality materials which can be reused or recycled.
- › Render the disused product unusable immediately to prevent subsequent accidents involving the product.
- › Dispose of the product in a proper, environmentally friendly manner (local regulations must be observed).

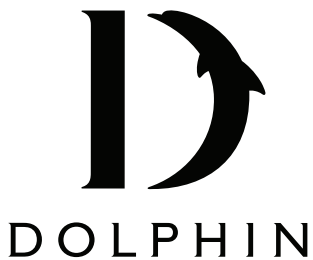

Dolphin Solutions Ltd

Southpoint, Compass Park, Bodiam,
Robertsbridge, TN32 5BS

Tel: +44 (0)1424 20 22 24

Fax: +44 (0)1424 205 200

info@dolphinsolutions.co.uk

www.dolphinsolutions.co.uk