



DS411.F

## **DOLPHIN INFORM UP AND OVER 90 DEGREE FOAM SOAP DISPENSER**

INSTALLATION AND MAINTENANCE GUIDE

### PRODUCT CODE

DS411.F.125 > 125mm Projection  
DS411.F.150 > 150mm Projection  
DS411.F.175 > 175mm Projection

## DS411.F

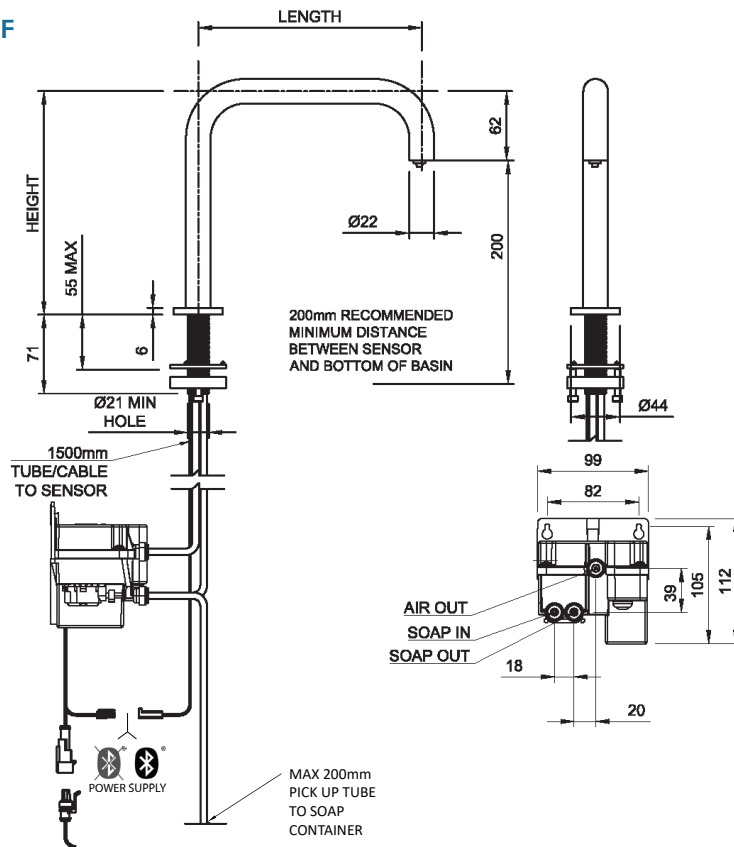

## TECHNICAL DATA

- › Dolphin InForm Up and Over 90 Degree Foam Soap Dispenser
- › Manufactured from high-quality, highly durable 1.4401 (316) Marine grade stainless steel.
- › Self-Monitoring Analysis and Recording Technology (SMART) allows the Facilities Manager to connect point to point via the Dolphin SMART App when used with the optional Bluetooth Adaptor (Sold separately -Order product code 26040 )
- › Infra-Red Touch Free Soap Dispenser for ultimate hygiene
- › Prevents cross contamination Sensor mounted in the body.
- › Dispenses 0.8ml of foam soap per operation
- › Power Supply: See page 6 for power supply and other options
- › Nominal Current: Less than 1mA (Less than 25mA with Bluetooth)
- › Nominal Power: Less than 1W
- › IP67 Connector

## Product Codes

- DS411.F.125 > 125mm Projection
- DS411.F.150 > 150mm Projection
- DS411.F.175 > 175mm Projection

## Coding Explained

### Style

DS411.F for Foam  
DS411.L for Liquid

### Projection

DS411.X.XXX.XXX.X

### Finish

- 1 Brushed Satin
  - 2 Mirror Polished
  - 3 PVD Brushed
  - 4 PVD Mirror
  - 5 Powder Coated
- DS411.F.XXX

### Colour

Suffix to end of code  
(Number allocated by Dolphin Solutions)

## Example Coding

DS411.150.1  
Strataplate Version  
150mm Projection  
Brushed Satin Finish

## Options

- Bluetooth 
- PVD
- Powder Coating

## PACK CONTENTS

1. Sensor Housing
2. Tail
3. Nozzle Housing
4. Body
5. Lock Nut M18
6. Rosette
7. Large Lock Washer
8. Non - Return Cartridge
9. Foaming Cartridge
10. Adaptor
11. Spout
12. Oring
13. M4 Grub Screw
14. M3 Grub Screw
15. M5 Screw
16. Large Oring
17. 6mm Tube Clear
18. Tubing

### Options



✓ ? Order 26040 seperately

### Standard

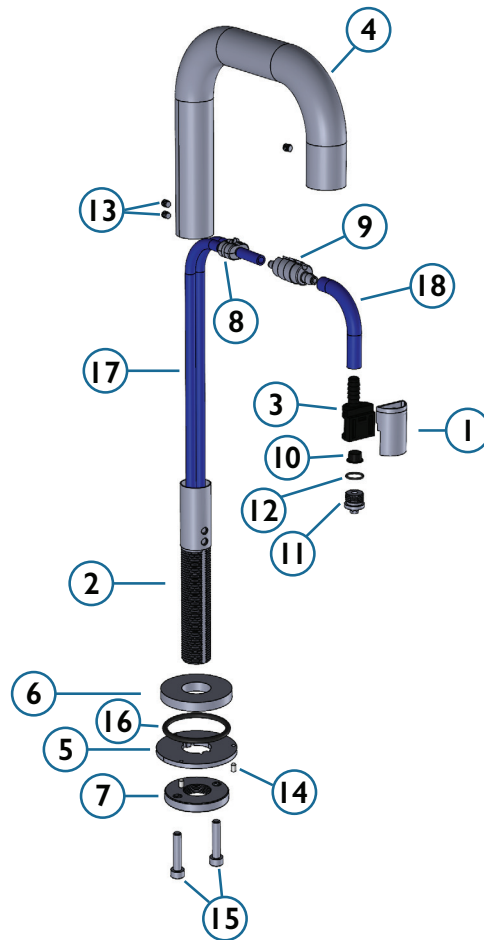

## PRE INSTALLATION

> Where possible check that all the components in the list above are present and that they are in good condition before installation. If any components are missing contact Dolphin Solutions.

>It is very important to allow permanent access to the mounting tail/nut of this product for future servicing and repair. Where this is not possible see our wall plate mounted products.

### ⚠ WARNING

> Highly reflective surfaces directly beneath the sensor of this product, in particular polished finish basin wastes/strainers, will cause false activation of the infrared sensors and can result in malfunction. We recommend Satin or Matt finish products which can be found on our website.

> Sitting water may also cause the sensor to activate

> All Electrical installation must be carried out by a qualified person and in accordance with applicable codes and regulations.

> Do not kink the supply hoses.

# INSTALLATION

## Step 1

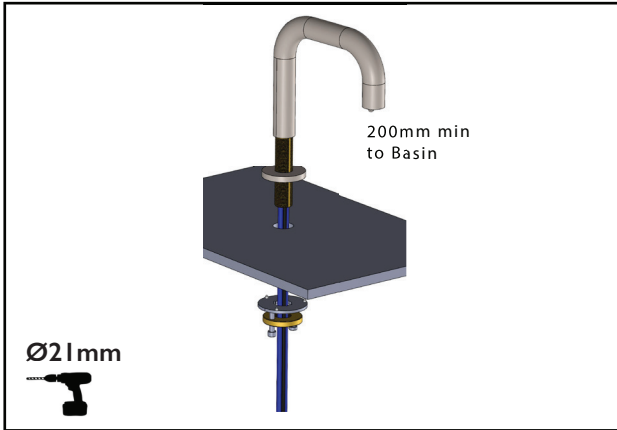

## Step 2

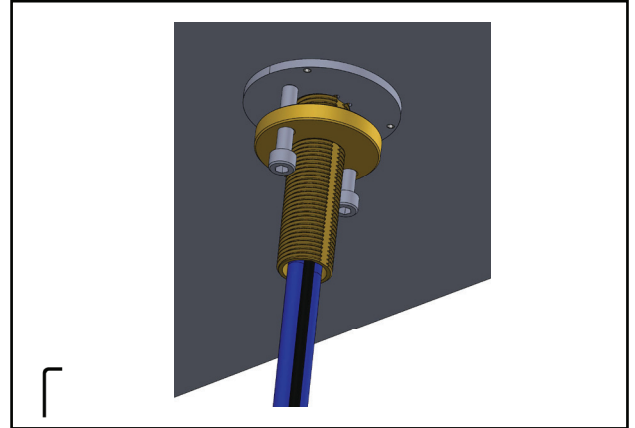

## Step 3

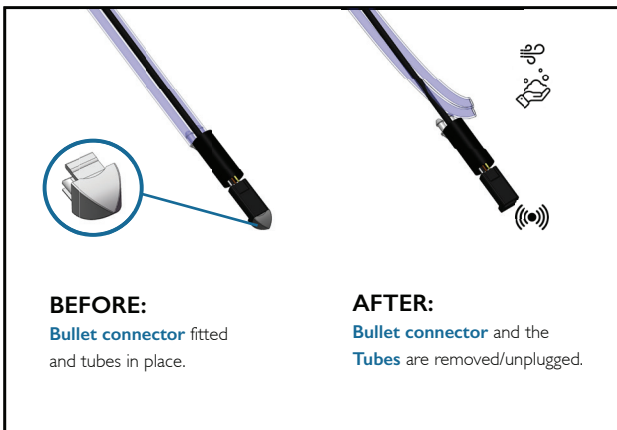

## Step 4

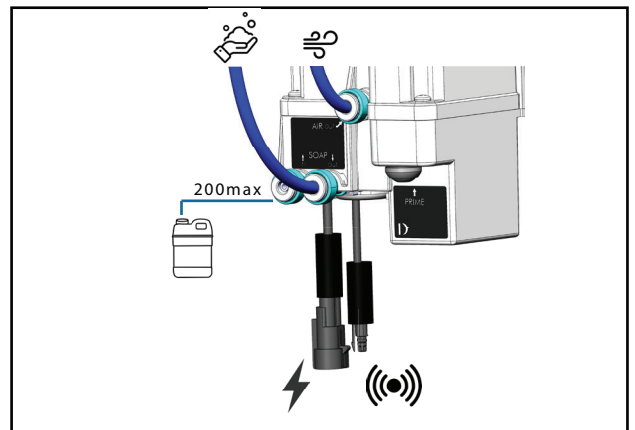

## Step 5

- > Switch on power supply - see page 6 for options
- > The Sensor is self adjusting.

Further adjustments can be made by purchasing the Bluetooth Adaptor and downloading the App

### Power Supply Options:

**26001** (is a universal adaptor; the user will get all regions pins with the one adaptor).

**26004 Hardwire psu**

## Step 6

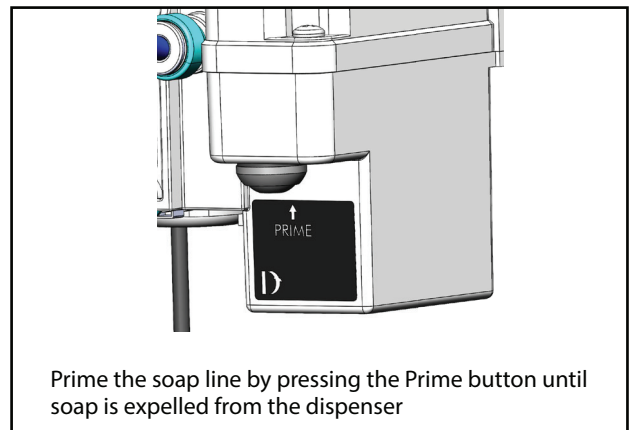

# SOAP CONTAINER OPTIONS

## 2 Litre Cartridge - Single Feed

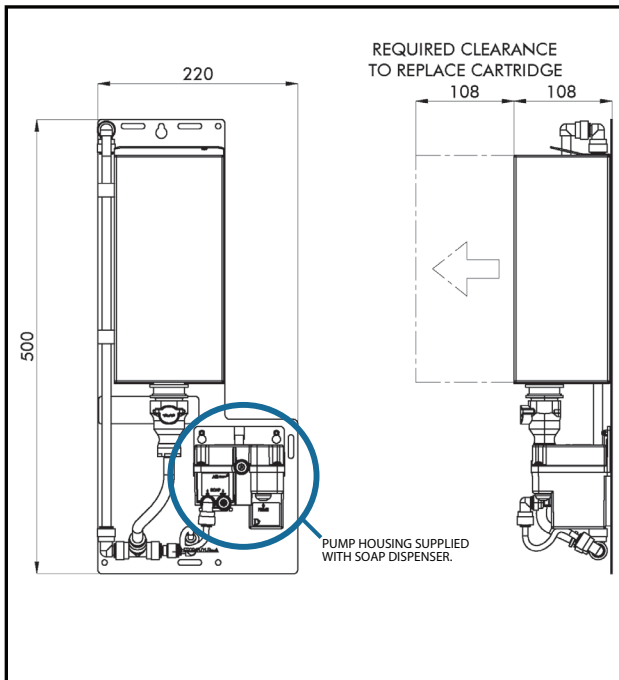

## 5 Litre - Multi Feed

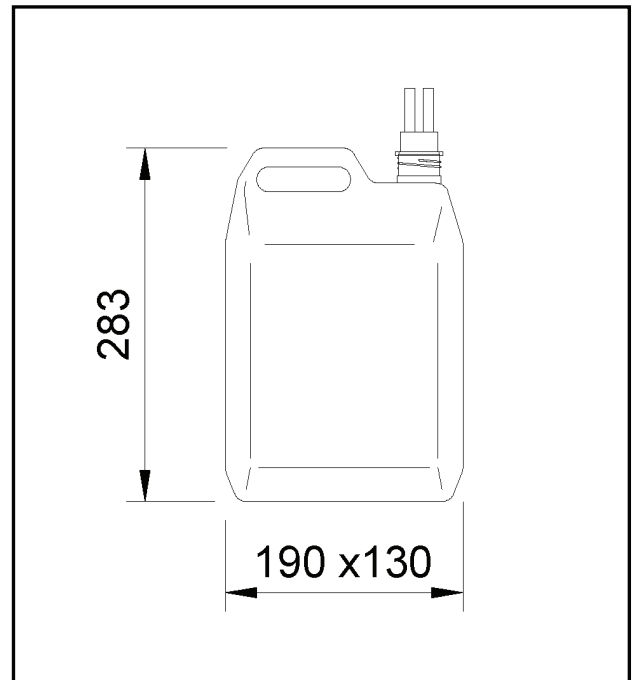

## 3.5 Litre Cartridge - Multi Feed

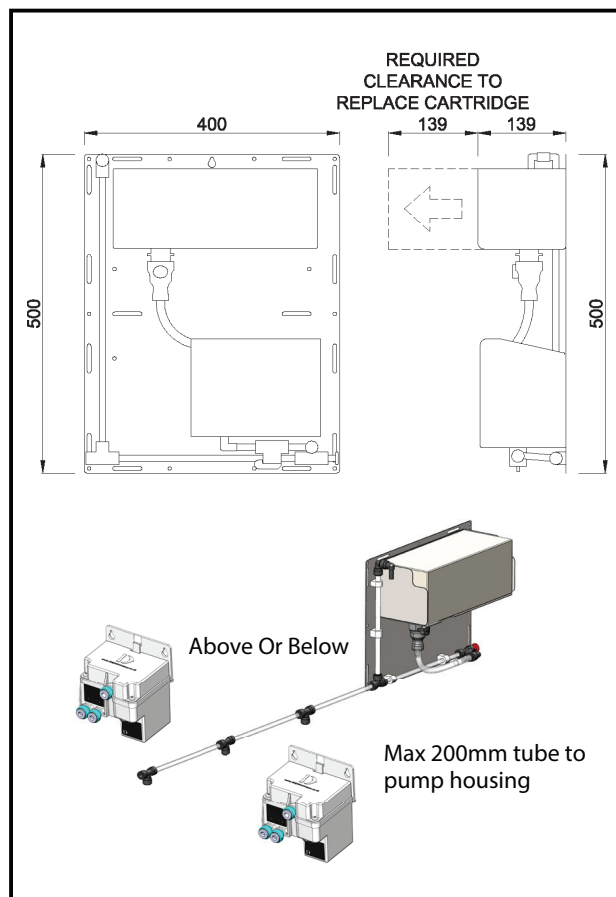

## MAINTENANCE

---

DO NOT use steel wool or cleansing agents containing alcohol, acid, abrasives or the like. Use of any prohibited cleaning or maintenance products or substances could damage the surface of the dispenser. For surface cleaning of Soap Dispenser use ONLY soap and water then wipe dry with a clean soft cloth. Protect Soap Dispenser from splattering of harsh cleaners when cleaning surroundings

## POWER SUPPLY OPTIONS

---

### MAINS ADPATOR PRODUCT CODE 26001

- Input voltage: 100 - 240V AC +/- 10%, 50 - 60 Hz
- Output voltage: 12V DC 1.0A 12.0W
- Standby Power Consumption 0.1W
- OUTPUT RIPPLE @At 20MHz, and output parallel a 47uF/50V electrolytic capacitors and a 0.1uF/50V ceramic capacitors 300mVp-p
- Certifications: IEC/EN62368
- 1m Cable

### HARDWARE POWER SUPPLY PRODUCT CODE 26004

- Input voltage: 100 - 240V AC +/- 10%, 50 - 60 Hz
- Output voltage: 12V DC 1.0A 12.0W
- @At 20MHz, and output parallel
- 1m Cable to m Cable (to Mains)

### BLUETOOTH ADAPTOR PRODUCT CODE 26040



Bluetooth® version 4.0

The of the app required for using the system must be installed on the control unit in advance. The App is available for free in the iTunes Store (requires an Apple account) and the Google Play store (requires a Google account).

For operation under adverse environments, in buildings / rooms with reinforced concrete walls, steel and iron frame, or near obstructions (eg furniture) made from metal, the Bluetooth reception can be disturbed and interrupted.

#### **Bluetooth®**

Power consumption: Less than 25mA

Output: Bluetooth® - Class 2

Bluetooth® - version: 4.0

Bluetooth® - Transmission distance: about 10m (depending on the environments)

Automatic safety shut-off: (10/20/60 seconds - adjustable) 20 s

Run-on time (0 - 10 s adjustable): 1 s

Detection Range - Levels 1 to 10 (10 = 120mm approx) 10