

BC200EV

DOLPHIN VERTICAL BABY CHANGING UNITS

INSTALLATION AND SAFETY INSTRUCTIONS



February 2024

D
DOLPHIN

BEFORE YOU BEGIN

VERY IMPORTANT. SAVE THESE INSTRUCTIONS FOR FUTURE REFERENCE. READ AND KEEP IN MIND ALL INSTRUCTIONS AND RECOMMENDATIONS DESCRIBED THROUGHOUT THIS MANUAL.







SAFETY INSTRUCTIONS

- › Only a qualified technician can install, adjust and maintain this baby changing station. Any operations performed on the changing station must be compliant with the safety laws and regulations, both European and local, that are in force at the time. Dolphin Solutions is not liable for damages caused by the improper installation, poor maintenance or misuse of this baby changing station.
- › It is very important that, once installed and put into operation, the baby changing station is periodically inspected in order to ensure that it remains firmly secured to the wall and it has not suffered any damage that may cause any harm to users. It is very important to make sure that the baby changing station opens and closes properly.
- › Any additional component or spare part required for the baby changing station should only be purchased from the manufacturer or from an authorized distributor.
- › Under no circumstances may the baby changing station be used if there are indications that any part of it is broken, torn or lost.
- › The baby changing station must be secured to a wall capable of withstanding the loads to which it will be subjected daily without a problem and the most appropriate wall fixings must be used for each type of wall.
- › The total maximum recommended weight for this changing station is 11 kg and babies up to 12 months acc. to EN 12221-1:2008+A1:2013 Type 1. The changing station has been tested with a load of 50 kg during 1 hour according to the point 5.7 of the EN 12221-2:2008+A1:2013 Standard. Excessive weight may create dangerous or unstable situations for the baby.
- › All assembly joints and wall fixings must always be properly tightened and inspected regularly to make sure that they are properly fastened.
- › It is very important to install the changing station away from sources of heat or open fire in order to avoid the risk of fire.
- › If the changing station is vandalized, it is very important to remove it from the wall and perform a thorough inspection of the unit and the wall where it should be installed in order to detect and solve any problem that may lead to an accident.
- › For better comfort and safety, sanitary liners should always be available in the changing station and the unit should be thoroughly cleaned daily in order to minimize the spread of infectious diseases.
- › Under no circumstance should the baby be left unattended at any time on top of the baby changing station.
- › Always place the baby in the centre of the changing station.
- › The baby changing station is designed to be used without any pillow. Please do not use pillow or any other device that could affect the baby placement on the changing station.

INSTALLATION INSTRUCTIONS

REQUIRED TOOLS

You will need the following tools for the installation of the baby changing station:

	Measuring tape in order to install the changing station to the appropriate height and distance
	Phillips Head Screwdriver in order to tighten the fasteners of the changing station
	A level in order for the changing station to be installed completely horizontal to the ground
	A pencil for the appropriate installation markings
	A drill to make all the necessary holes for the installation
	1 Ø 10 mm masonry drill bit (a special drill for brick, masonry or cement walls with widia tip).

FIXINGS SUPPLIED

The following fixings are supplied with the baby changing station:

	Six self-tapping Philips screws (DIN 7981/C A2 of Ø6.3x70 mm) for fixing the changing station to the wall
	Six Ø10mm nylon plugs to insert into the installation holes of the changing station
	Four flat washers (DIN125 M8 A2) to be mounted with four Ø6.3x70 mm self-tapping Philips screws below the metal structure
	Four blunt Philips screws (DIN7985 A2 M4x8 mm) to fasten the liner dispenser to the metal wall structure
	Four flat washers (DIN125 M4 A2) to be mounted with four blunt Philips screws (M4x8 mm) to fasten the liner dispenser

INSTALLATION INSTRUCTIONS

Step 1. Material inspection

It is very important to carry out a visual inspection of the packaging of the baby changing station in order to ensure that it has not suffered any damage during transport and handling. If damage to the packaging is found, the changing station should be carefully inspected to see if it has suffered any damage. **UNDER NO CIRCUMSTANCE SHOULD THE BABY CHANGING STATION BE INSTALLED IF ANY DAMAGE IS FOUND.**

Remove all packaging material and check if any assembly component (bed with wall installation structure and sanitary liner dispenser) or any hardware component (see table of fixings supplied) is missing.

Step 2. Preparation of the installation surface

Once the material is unpacked and inspected, choose the area on the wall where the baby changing station will be installed. It is very important to keep in mind and respect the operating distances indicated in the figure below, which are 75 mm on either side of the chassis for fixing the changing station to the wall and 895 mm of the changing station bed, when it is open, from the wall.

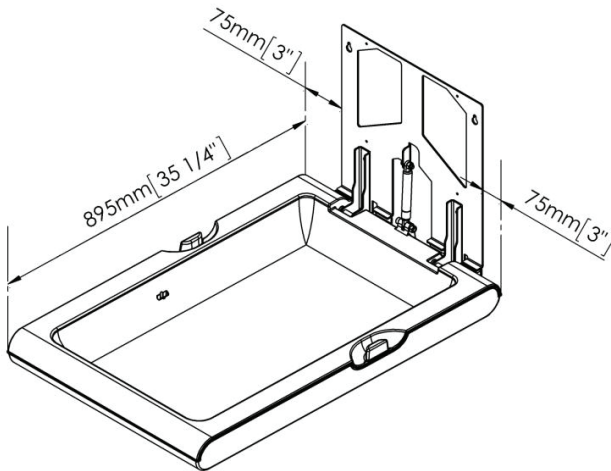

The recommended installation height is 800 mm from the ground to the lowest part of the changing station. The following sketch shows the height at which the holes should be made in order for the changing station to be installed at the recommended height:

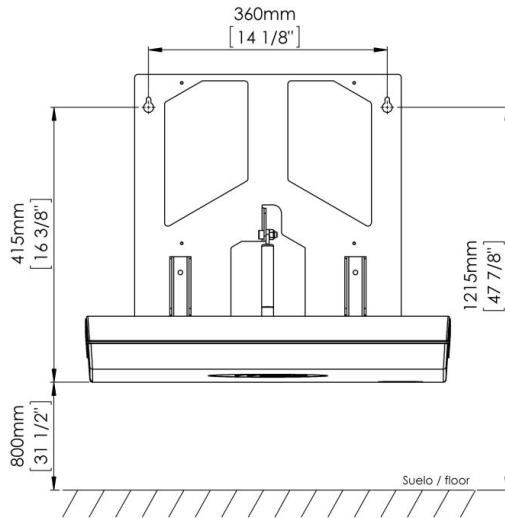

Following the above scheme, using the pencil, mark on the wall the top two holes of the changing station's holding structure. It is very important to make sure that the locations marked with the pencil for the mounting holes are at the same level before drilling the holes.

Installation according to ADA regulations.

If it is required that the installation complies with the ADA regulations (USA), the installation should be made taking into account the following installation dimensions.

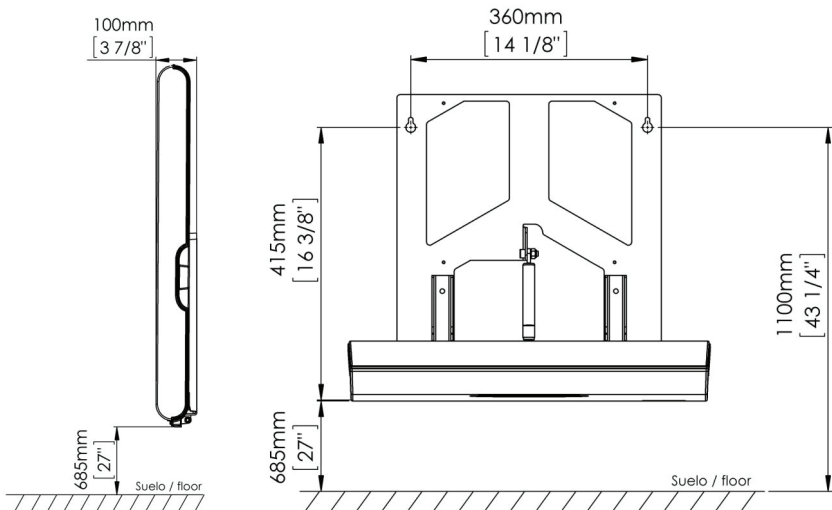

Step 3. Installation of the changing station's bed and holding structure on the wall.

Installation on brick, masonry or cement wall.

Using the masonry bit, make the two previously marked $\varnothing 10$ mm holes for the top part of the changing station, at a minimum depth of 70 mm.

Clean the dust off the two holes and insert the two $\varnothing 10$ mm nylon plugs into them.

Screw two of the $\varnothing 6.3 \times 70$ mm mounting screws into the two previously placed plugs, without reaching the bottom, leaving a gap of about 5 mm between the screw head and the wall.

Hang the changing station's holding structure from the two previously placed screws, making sure that the unit is perfectly levelled. When you have made sure that the changing station is perfectly levelled, tighten the top two screws completely.

Use the four lower holes of the changing station's holding structure as a guide to mark the position of the remaining four holes.

Loosen the upper screws and remove the changing station.

Using the previously made markings as reference, drill the four lower holes with the $\varnothing 10$ mm drill at a minimum depth of 70 mm.

Once completed, proceed with cleaning the holes and placing the remaining four $\varnothing 10$ mm nylon plugs.

Put the changing station back on the top two screws and fix the structure to the wall with the four $\varnothing 6.3 \times 70$ mm screws and the four DIN125 M8 washers of the lower holes, then fully tighten the top two screws, the distribution of the components is shown in the following figure:

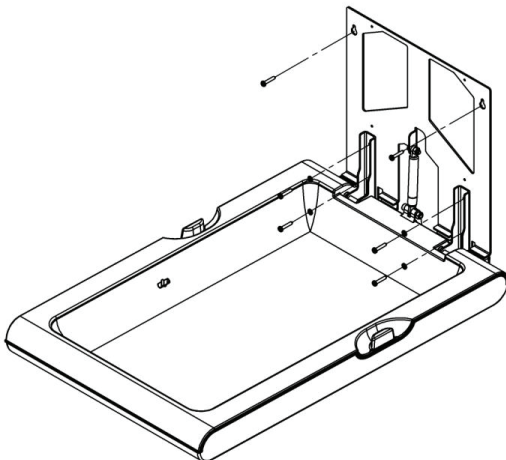

Make sure that the six screws securing the unit to the wall have been properly tightened and that the changing station is firmly fixed to the wall.

Installation on plasterboard or hollow wall.

The fixing systems supplied with this changing station are not suitable for installation on plasterboard or hollow walls.

In order to install the unit on this type of wall, fastening anchors and tools specific for plasterboard or hollow walls must be used.

Due to the problems posed by installations on this type of walls, with regard to fixing, it is recommended that the installation is carried out by technicians specialized in installations on this type of walls. Dolphin Solutions is not responsible for the installation of its changing stations on plasterboard or hollow walls.

Step 4. Mounting the liner dispenser on the changing station holding structure

Take the liner dispenser and, after verifying that it is not damaged or scratched, place it on the metal structure following the sequence of steps shown below and thus ensuring its proper position with the metal shafts.

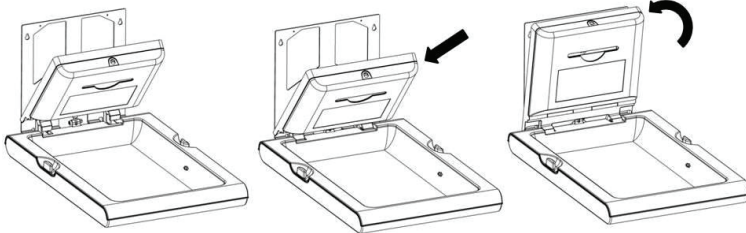

Open the liner dispenser with the special key provided. The four holes for mounting the liner dispenser on the holding structure of the changing station will be visible.

Fit the dispenser to the holding structure of the changing station and align the mounting holes of the dispenser:

Fix the liner dispenser to the holding structure of the changing station using the four M4x8mm screws and the four DINI25 M4 flat washers, as shown in the figure. Check and make sure it has been properly fixed.

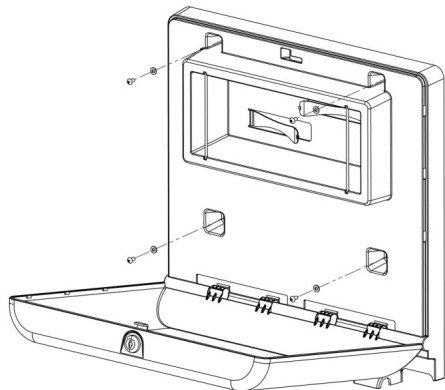

Step 5. Final revision before commissioning

Thoroughly clean and disinfect the baby changing station. It is very important to verify that the unit opens and closes smoothly and that no damage has been caused during installation of the changing. In summary, it is very important to verify, once the installation of the baby changing station is complete, that it is in perfect condition to be used without any problems.

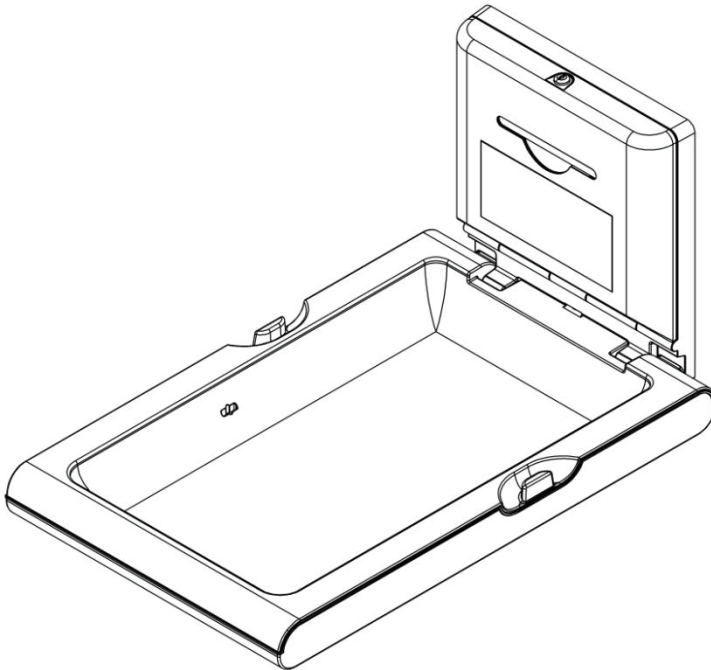

BASIC EXPLODED VIEW

Remember that any additional component or spare part required for the baby changing station should only be purchased from the manufacturer or an authorized distributor.

COMPONENT	No.
Label	1
Shock absorber BC200EV	2
Lock + key	3
Key	4 </td
Protective liners	5
Shock absorber	6

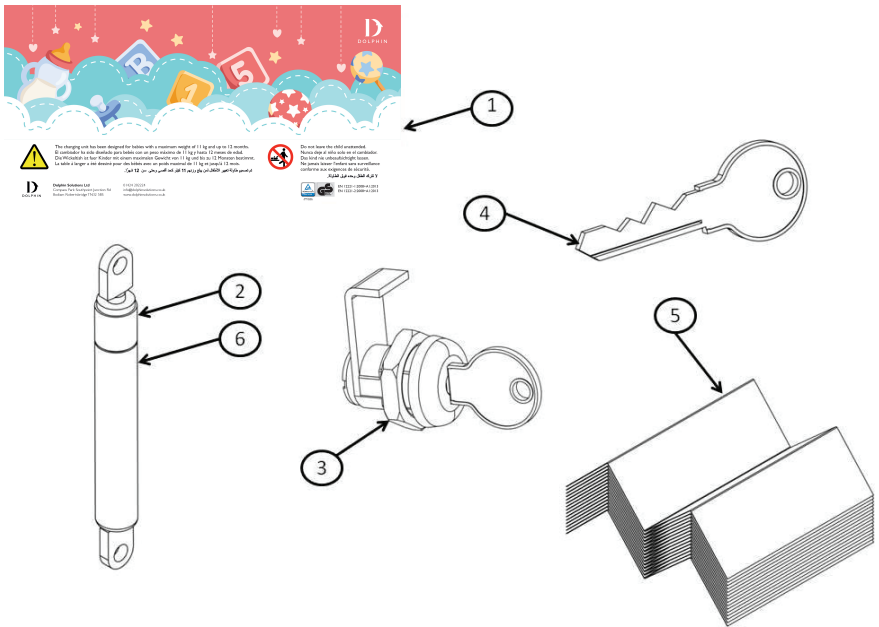

RECOMMENDATIONS

FOR PREVENTIVE MAINTENANCE AND CLEANING

Proper preventive maintenance and careful cleaning are essential for an appropriate, clean and safe product use.

For proper maintenance, follow these steps:

- › Inspect the components of the baby changing station: make sure that there are no cracks, dents or any other sign that would suggest any fault in the product.
- › Inspect the opening of the station: open and close the tray, make sure that it doesn't open beyond 90° and that when raising the tray, once past 45°, it automatically closes completely. The movements should be smooth and continuous, otherwise it is possible that the shock absorber is not functioning properly.

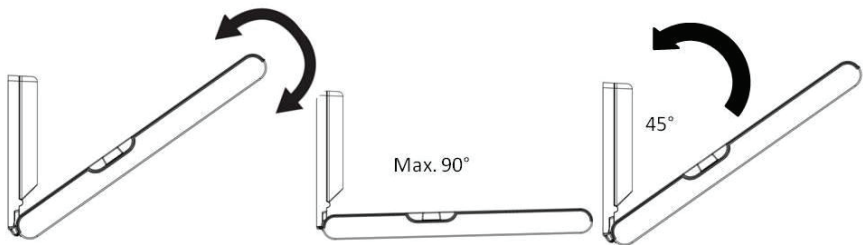

- › Inspect the wall mounting: it is one of the most important points, make sure that it is firmly fixed and that there are no gaps or significant movement between the fixed portion of the changing station and the wall.
- › Inspect the fastening of the liner dispenser to the metal structure: open the dispenser cover and check that the 4 fixing screws are tightened with their respective washers.
- › Inspect the label: if it is missing, damaged, illegible or not properly attached, a new one should be placed.

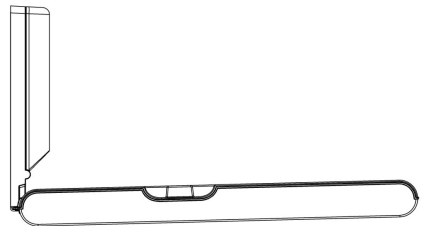



The changing unit has been designed for babies with a maximum weight of 11 kg and up to 12 months.
 El cambiador ha sido diseñado para bebés con un peso máximo de 11 kg y hasta 12 meses de edad.
 Die Wickeltisch ist fuer Kinder mit einem maximalen Gewicht von 11 kg und bis zu 12 Monaten bestimmt.
 La table à langer a été dessinée pour des bébés avec un poids maximal de 11 kg et jusqu'à 12 mois.
 تم تصميم طاولة تغيير الأطفال لمن يبلغ وزنه 11 كغار كحد أقصى وحتى سن 12 شهراً.



Do not leave the child unattended.
 Nunca deje al niño solo en el cambiador.
 Das Kind nie unbeaufsichtigt lassen.
 Ne jamais laisser l'enfant sans surveillance
 conforme aux exigences de sécurité.
 لا تترك الطفل وحده فوق الطاولة.



Dolphin Solutions Ltd
 Campus Park, Southpoint Junction Rd
 Boddam, Rotherbridge TN32 5BS

01424 202224
 info@dolphinsolutions.co.uk
 www.dolphinsolutions.co.uk



EN 12221-1:2008+A1:2013
 EN 12221-2:2008+A1:2013

For proper cleaning, follow these steps:

- › In order to avoid contact with the detergent, it is recommended to remove the liners from their housing before cleaning.
- › Clean all plastic pieces of the changing station using antibacterial soap.
- › On the BC200EV model, avoid contacting the stainless steel front with the antibacterial soap; it has to be cleaned with a standard stainless steel cleaner and a soft cloth.
- › Remove the soap residue with a dry cloth, making sure that the cleaning has been effective and that there are no residues of dirt or soap.
- › After the changing station has been dried, put the liners back in their housing and close the front cover with the lock.
- › Carry out a final visual inspection to make sure that the baby changing station has been properly cleaned.
- › Leave the changing station in a closed position.

WARNING



Never leave a child unattended on top of the baby changing station.



This changing station is designed exclusively for babies up to 12 months of age and weighing less than 11kg.



Placing packages and/or accessories on top of the changing station can destabilize it.



Dolphin Solutions Ltd

Southpoint, Compass Park, Bodiam,
Robertsbridge, TN32 5BS

Tel: +44 (0)1424 20 22 24

Fax: +44 (0)1424 205 200

info@dolphinsolutions.co.uk

www.dolphinsolutions.co.uk